



Instructions for the following series products:
Evolution Counterweight System

Model No. 7255000

USER INSTRUCTION MANUAL EVOLUTION COUNTERWEIGHT SYSTEM

Figure 1 - Assembled Evolution Counterweight System

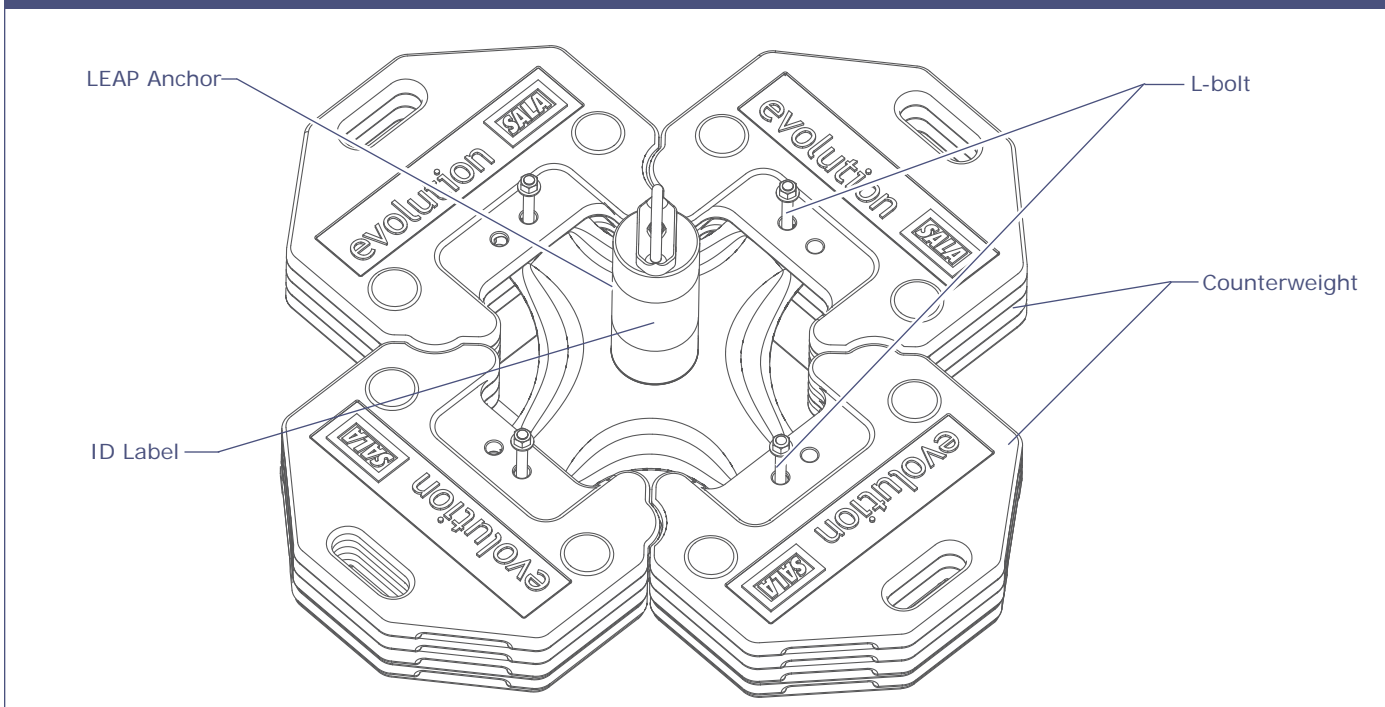

WARNING: This product is part of a fall arrest system. These instructions must be provided to all users and rescuers (see section 8 Terminology) using this equipment. The user must read and understand these instructions before using this equipment. The user must follow the manufacturer's instructions for each component of the system. Manufacturer's instructions must be followed for proper use and maintenance of this equipment. Alterations or misuse of this equipment, or failure to follow instructions, may result in serious injury or death.

IMPORTANT: If you have questions on the use, care, or suitability of this equipment for your application, contact DBI-SALA.

IMPORTANT: Before using this equipment, record the product identification information from the ID label into the inspection and maintenance log in section 10.0 of this manual.

1.0 APPLICATION

1.1 PURPOSE: The Evolution Counterweight System is designed for use as an anchoring means for a personal fall arrest system (PFAS) for a person working on flat roofs or structures.

1.2 LIMITATIONS: The following limits apply to the installation and use of Evolution Counterweight System. Other limitations may apply:

- A. HORIZONTAL LIFELINE:** The Evolution Counterweight System is not rated for use as an anchor for a horizontal lifeline.
- B. SYSTEM CAPACITY:** The maximum capacity of the Evolution Counterweight System is one person with a maximum combined weight including tools and clothing, of 310 lbs. (141 kg).
- C. ROOF TYPES:** The Evolution Counterweight System is approved for use on the following types of roofs: concrete, single ply membrane, bitumen membrane, asphalt sanded, and asphalt stone chippings.

If you want to use the system on any other type of roofing surface, contact DBI-SALA for further recommendations.

- D. ROOF LOAD:** The roof must be able to support a static load of 720 lbs.
 - E. ROOF CONDITIONS:** The Evolution Counterweight Anchor System must not be used in adverse weather conditions. The roof surface must be free of frost, snow, standing water, grease or oil, or any other type of lubricating or friction reducing materials.
 - F. PERSONAL FALL ARREST SYSTEM:** PFASs used with this roof anchor must meet applicable OSHA, state, federal and ANSI requirements. PFASs incorporating a full body harness must be capable of arresting a worker's fall with a maximum arresting force of no greater than 1,800 lbs. (8 kN) and limit the free fall distance to 6 ft. (1.8 m) or less. The deceleration distance for a PFAS must be 42 inches (1.1 m) or less [47 inches (1.2 m) in Canada]. Reference ANSI Z359.1, OSHA and CSA Z259.11 requirements. The system must be rigged in a way that limits free fall to 6 ft. or less. Contact DBI-SALA if you have questions or concerns regarding free fall limits.
 - G. ENVIRONMENTAL HAZARDS:** Use of this equipment in areas where environmental hazards exist may require additional precautions be taken to reduce the possibility of injury to the user or damage to the equipment. Hazards may include, but are not limited to: high heat, extreme cold, caustic chemicals, corrosive environments, high voltage power lines, explosive or toxic gases, moving machinery, or sharp edges. Contact DBI-SALA if you have questions about using this equipment where environmental hazards exist.
 - H. TRAINING:** This equipment must be installed and used by persons who have been properly trained in its correct application and use. Installation and use of this equipment must be supervised by a qualified person, as defined by OSHA fall protection standards.
- 1.3 APPLICABLE STANDARDS:** Refer to national Standards including ANSI Z359 (.0, .1, .2, .3, and .4) family of standards on fall protection, ANSI A10.32, and applicable local, state and federal (OSHA) requirements governing occupational safety for more information about work positioning systems. Refer to CSA Z259.13 in Canada for more information on personal fall arrest systems and associated components.

2.0 SYSTEM REQUIREMENTS

- 2.1 COMPATIBILITY OF COMPONENTS:** DBI-SALA equipment is designed for use with DBI-SALA approved components and subsystems only. Substitutions or replacements made with non-approved components or subsystems may jeopardize compatibility of equipment and may effect the safety and reliability of the complete system.
- 2.2 COMPATIBILITY OF CONNECTORS:** Connectors are considered to be compatible with connecting elements when they have been designed to work together in such a way that their sizes and shapes do not cause their gate mechanisms to inadvertently open regardless of how they become oriented. Contact DBI-SALA if you have any questions about compatibility.

Connectors (hooks, carabiners, and D-rings) must be capable of supporting at least 5,000 lbs. (22.2 kN). Connectors must be compatible with the anchorage or other system components. Do not use equipment that is not compatible. Non-compatible connectors may unintentionally disengage. See Figure 2. Connectors must be compatible in size, shape, and strength. Self locking snap hooks and carabiners are required by ANSI Z359.1 and OSHA and CSA Z259.12 in Canada.

Figure 2 - Unintentional Disengagement (Roll-out)

If the connecting element that a snap hook (shown) or carabiner attaches to is undersized or irregular in shape, a situation could occur where the connecting element applies a force to the gate of the snap hook or carabiner. This force may cause the gate (of either a self-locking or a non-locking snap hook) to open, allowing the snap hook or carabiner to disengage from the connecting point.

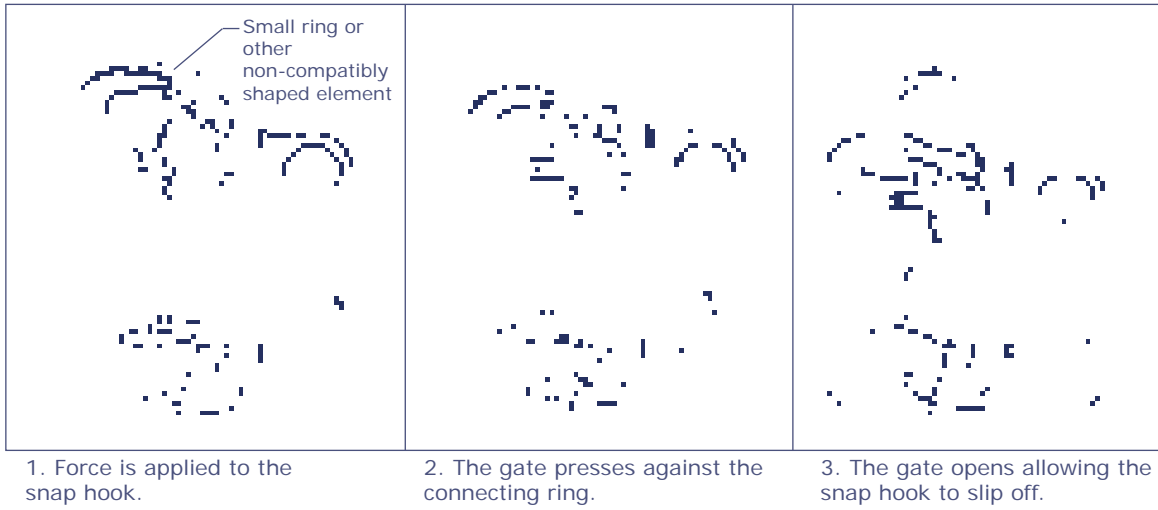

2.3 MAKING CONNECTIONS: Only use self-locking snap hooks and carabiners with this equipment. Only use connectors that are suitable to each application. Ensure all connections are compatible in size, shape and strength. Do not use equipment that is not compatible. Ensure all connectors are fully closed and locked.

DBI-SALA connectors (snap hooks and carabiners) are designed to be used only as specified in each product’s user’s instructions. See Figure 3 for inappropriate connections. DBI-SALA snap hooks and carabiners should not be connected:

- A. To a D-ring to which another connector is attached.
- B. In a manner that would result in a load on the gate.

NOTE: Large throat opening snap hooks should not be connected to standard size D-rings or similar objects which will result in a load on the gate if the hook or D-ring twists or rotates. Large throat snap hooks are designed for use on fixed structural elements such as rebar or cross members that are not shaped in a way that can capture the gate of the hook.

- C. In a false engagement, where features that protrude from the snap hook or carabiner catch on the anchor and without visual confirmation seems to be fully engaged to the anchor point.
- D. To each other.
- E. Directly to webbing or rope lanyard or tie-back (unless the manufacturer’s instructions for both the lanyard and connector specifically allows such a connection).
- F. To any object which is shaped or dimensioned such that the snap hook or carabiner will not close and lock, or that roll-out could occur.

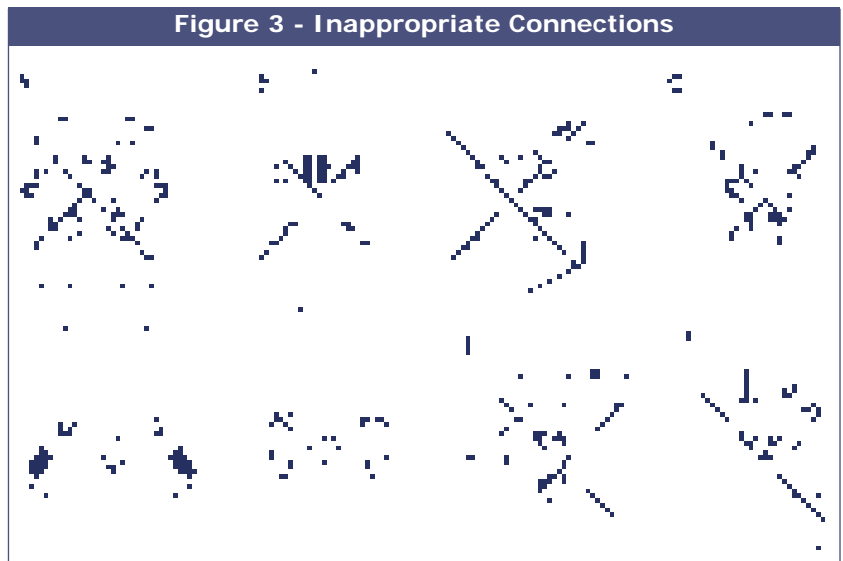

2.4 STRUCTURE LOAD: The structure supporting these anchorage points must be rigid, flat pitch, and capable of supporting at least 5,000 lbs. (22.2 kN) in the direction of potential fall arrest.

3.0 ASSEMBLY AND USE

WARNING: Do not alter or intentionally misuse this equipment. Consult with DBI-SALA if using this equipment in combination with components or subsystems other than those described in this manual. Some subsystems and components combinations may interfere with the proper operation of this equipment. Use caution when using this equipment around moving machinery, electrical and chemical hazards, and sharp edges.

WARNING: Working at height has inherent risks. Some risks are noted here but are not limited to the following: falling, suspension/prolonged suspension, striking objects, and unconsciousness. In the event of a fall arrest and/or subsequent rescue (emergency) situation, some personal medical conditions may affect your safety. Medical conditions identified as risky for this type of activity include but are not limited to the following: heart disease, high blood pressure, vertigo, epilepsy, drug or alcohol dependence, psychiatric illness, impaired limb function and balance issues. We recommend that your employer/physician determine if you are fit to handle normal and emergency use of this equipment.

3.1 BEFORE EACH USE inspect this equipment according to steps listed in section 5.3. Do not use this equipment if inspection reveals an unsafe or defective condition. Plan your use of the fall protection system prior to exposing workers to dangerous situations. Consider all factors affecting your safety before using this system.

- A. Read and understand all manufacturer's instructions for each component of the personal fall arrest system. All DBI-SALA harnesses and connecting subsystems are supplied with separate user instructions. Keep all instructions for future reference.
- B. Review sections 1.0 and 2.0 to ensure system limitations and other requirements have been adhered to. Review applicable information regarding system clearance criteria, and ensure changes have not been made to the system installation (i.e. length), or occurred at the job site, that could affect the required fall clearance. Do not use the system if changes are required.

3.2 PLAN your fall arrest system before starting your work. Take into consideration factors affecting your safety at any time during use. The following list gives some important points you must consider when planning your system:

- A. **ANCHORAGE:** Select an anchorage point that is rigid and capable of supporting the required loads. See section 2.4. Locate the roof anchor in accordance with section 3.3.
- B. **OTHER CONSIDERATIONS:**

- Place the Counterweight System at least 8 ft (2.5 m) away from any edge or opening. See Figure 4.
- Personal fall arrest systems must be rigged to limit any free fall to a maximum of 6 ft. (1.8 m) (OSHA and ANSI Z359.1) (see section 1.2 F).
- Avoid working above your anchorage level since an increased free fall distance will result.
- Avoid working where your line may cross or tangle with that of another worker or another object.
- Do not allow the lifeline to pass under arms or between legs.
- Never clamp, knot or otherwise prevent the lifeline from retracting or being taut, avoid slack line.

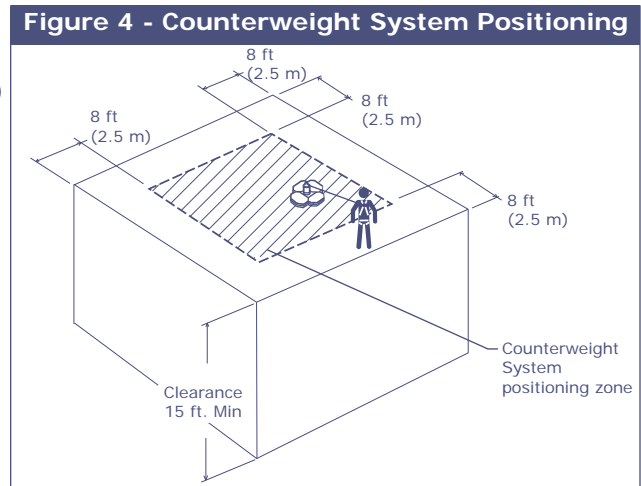

IMPORTANT: Do not lengthen the SRL by connecting a lanyard or similar component without consulting DBI-SALA.

- C. **TOTAL FALL DISTANCE:** Should a fall occur, there must be at least 15 ft of clearance in the fall area to arrest the fall before striking the ground or other object (see Figure 4). The total fall distance is the distance measured from the onset of a fall to the point where the fall is arrested. A number of factors can influence the total fall distance including; user's weight, anchorage location relative to the fall (swing fall), body support with sliding D-ring, and the type of fall arrest equipment you attach to the LEAP anchor. For specific clearance requirements read and follow the manufacturers's instructions for your fall arrest equipment.
- D. **SWING FALLS:** See Figure 5. Swing falls occur when the anchorage point is not directly above the point where a fall occurs. The force of striking an object while swinging (horizontal speed of the user due to the pendulum affect) can be great and may cause serious injury. Swing falls can be minimized by working as close to the anchorage point as possible. In a swing fall situation, the total vertical fall

distance of the user will be greater than if the user had fallen vertically directly below the anchorage point. The user must therefore account for an increase in the total free fall distance and the area needed to safely arrest the fall.

The SRL (if applicable) will activate (lock-up) regardless of its orientation and location relative to the user's position, however, a commonly followed guideline is work as directly between the anchorage point and roof edge as possible. Do not captivate the lifeline of an SRL, it may affect the performance of its braking. If a swing fall hazard exists in your application, contact DBI-SALA before proceeding.

- E. **SHARP EDGES:** Avoid working where the connecting subsystem (i.e. SRL, full body harness, lanyard, lifeline, etc.) or other system components will be in contact with, or abrade against unprotected sharp edges. See Figure 6. If working with this equipment near sharp edges is unavoidable, protection against cutting must be provided by using a heavy pad or other means over the exposed sharp edge. If you are not using the Leading Edge SRL (PN 3504500), it is recommended that an energy absorber (PN 1220362) be installed in-line between the harness and the self retracting lifeline to further protect the worker. Compatibility and total fall distance issues must be considered if this is done. Contact DBI-SALA before using in-line energy absorbing components or lanyards with self retracting lifelines.
- F. **RESCUE:** Should a fall occur, the user (employer) must have a rescue plan and the means at hand to implement it.
- G. **AFTER A FALL:** Any equipment which has been subjected to the forces of arresting a fall must be removed from service immediately and destroyed or contact a factory authorized service center for repair.

WARNING: Read and follow the manufacturer's instructions for associated equipment (i.e. SRL, full body harness, lanyard, lifeline, etc.) used in your personal fall arrest system.

Figure 5 - Swing Falls

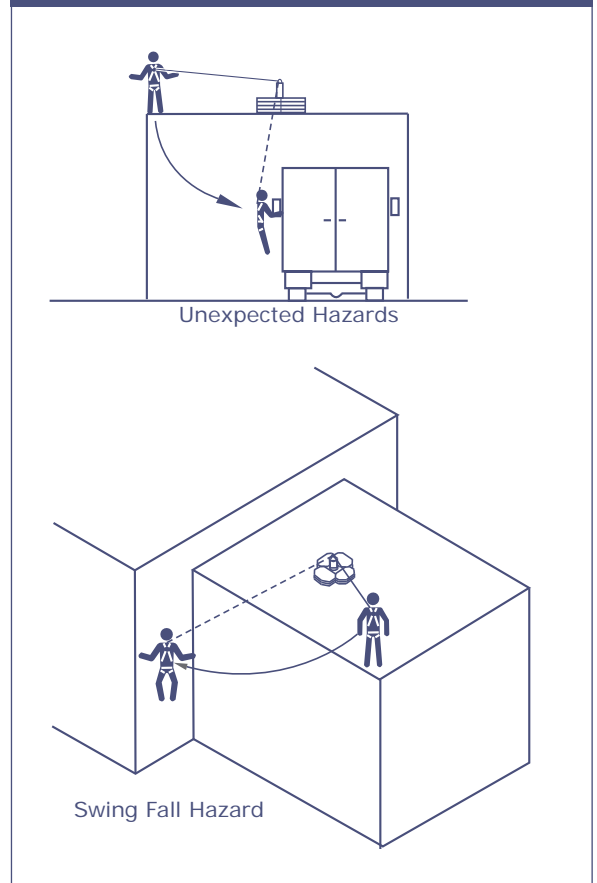

Figure 6 - Sharp Edges

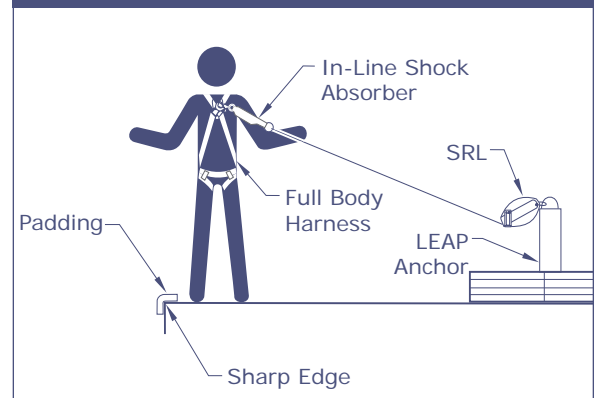
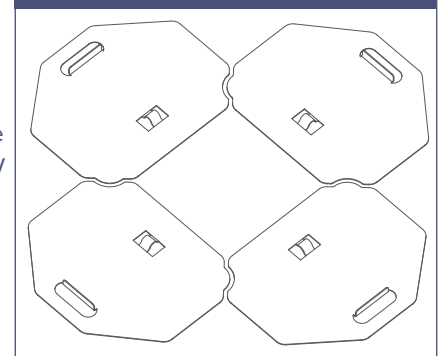

Figure 7 - Base Plate Layout



3.3 SYSTEM ASSEMBLY: Figure 1 shows the Evolution Counterweight System Assembled

- Step 1. Determine the location of the anchorage. The anchorage must be at least 8 ft. (2.5 m) away from the edge of the structure (or any openings such as skylights) and as close as possible to the work area. See Figure 4.
- Step 2. Sweep the installation area free of loose materials, then layout four rubberized plates on a flat surface as shown in Figure 7.

Step 3. Insert the "L" Bolts into the raised slots (see Figure 7). Alternate the direction of each L-bolt. See Figure 8.

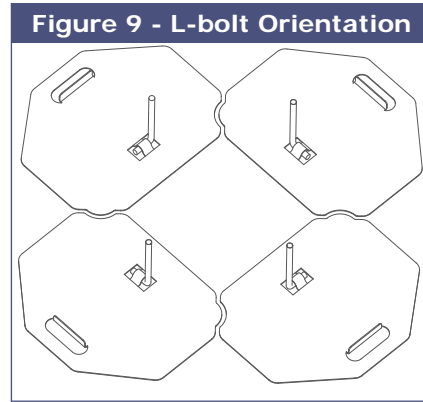
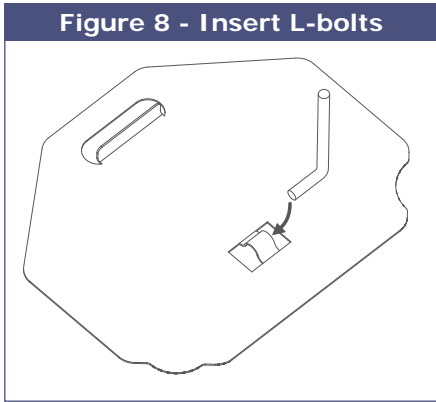

Step 4. Install the LEAP Anchor to ensure the L-bolts are oriented correctly and the D-ring on the LEAP Anchor will face the desired direction when installation is complete. See Figure 9.

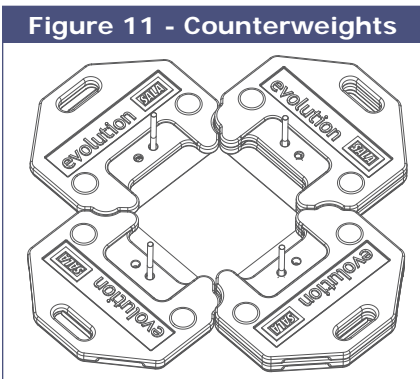
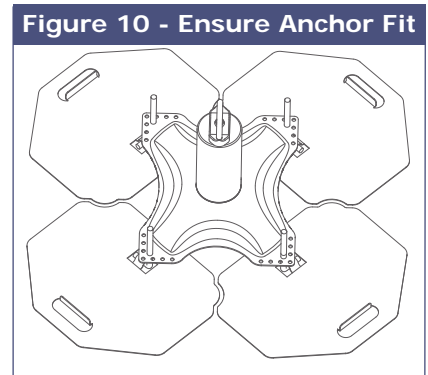

Step 5. Remove the LEAP Anchor and begin to assemble the counterweights onto the base plates, with the L-bolt protruding through the matching hole.
For concrete, single-ply membrane, and bitumen membrane, stack three counterweights on each base plate. For asphalt sanded and asphalt stone chippings, stack four counterweights on each base plate. See Figure 10.

Step 6. Assemble the LEAP Anchor onto the L-bolts and counterweights. Make sure each bolt passes through one of the 1/2 in. diameter mounting holes in the base plate of the LEAP Anchor. See Figure 11.

Step 7. Assemble one more layer of counterweights over the LEAP Anchor base, then apply a washer and nut to each of the L-bolts. Hand tighten all four nuts snugly. See Figure 12.

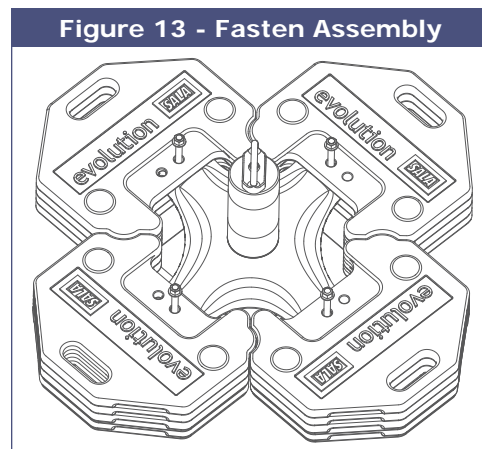
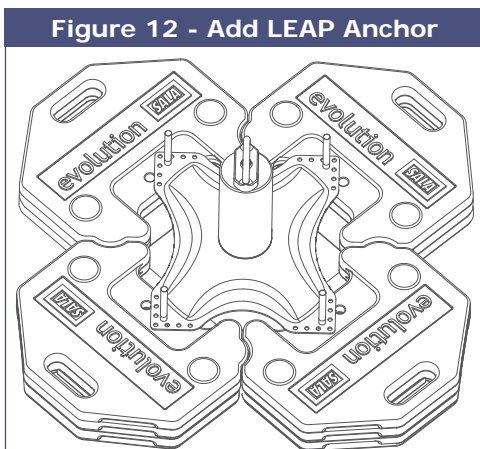

3.4 BODY SUPPORT: When using the DBI-SALA swiveling roof anchor, it is recommended that a full body harness be worn. For general fall protection use, connect to the D-ring on the back between the shoulders (dorsal D-ring).

IMPORTANT: Body belts are not allowed for free fall situations. Body belts increase the risk of injury during fall arrest in comparison to a full body harness. Limited suspension time and the potential for improperly wearing a body belt may result in added danger to the user's health.

3.5 CONNECTING TO THE LEAP ANCHOR: Figure 13 illustrates the proper connection of typical fall arrest equipment to the LEAP anchor. Always protect the lifeline from abrading against sharp or abrasive surfaces on the roof. Make sure all the connections are compatible in size, shape and strength. Never connect more than one personal protective system to any single LEAP anchor at a time.

SRL: Connection to the installed LEAP anchor may be made by attaching the self locking snap hook at the end of the SRL lifeline to the back dorsal D-ring (fall arrest attachment point) of the user's body support (i.e. full body harness). When connecting, make sure the connections are fully closed and locked. Review section 3.2 if using an SRL near sharp edges.

ENERGY ABSORBING LANYARDS OR LIFELINE: Connect the energy absorbing end of the lanyard to the back D-ring on the full body harness (see section 3.4). See manufacturer's instruction for more information.

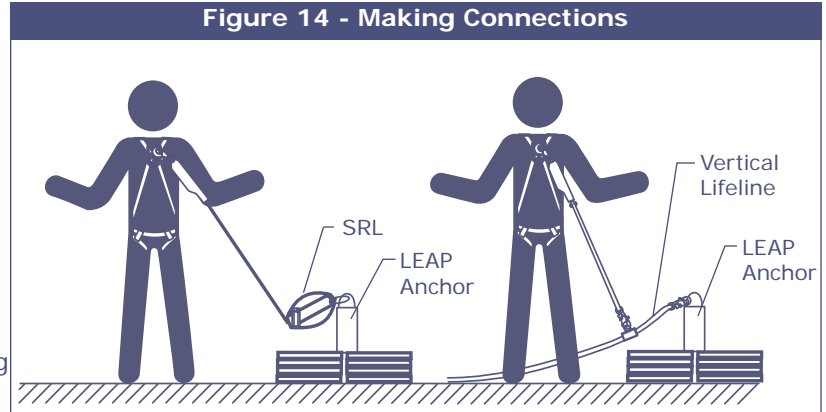

3.6 NORMAL OPERATION: Once attached, the worker is free to move about within the recommended working areas.

SRL: Should a fall occur, a speed sensing brake system will activate, stopping the fall and absorbing much of the energy created. Sudden or quick movements should be avoided during the normal work operation since this may cause the SRL to lock-up.

ENERGY ABSORBING LANYARD: Should a fall occur, the energy absorber will deploy, stopping the fall and absorbing much of the energy created.

If a fall has been arrested, the system must be taken out of service and inspected, see section 5.0.

4.0 TRAINING

4.1 It is the responsibility of all users of this equipment to understand these instructions, and are trained in the correct installation, use, and maintenance of this equipment. These individuals must be aware of the consequences of improper installation or use of this equipment. This user manual is not a substitute for a comprehensive training program. Training must be provided on a periodic basis to ensure proficiency of the users.

5.0 INSPECTION

5.1 BEFORE EACH INSTALLATION: Inspect the counterweight components, and other system components according to these or other manufacturer's instructions. System components must be formally inspected by a qualified person (other than the user) at least annually. Formal inspections should concentrate on visible signs of deterioration or damage to the system components. Items found to be defective must be replaced. Do not use components if inspection reveals an unsafe or defective condition. Record results of each inspection in the inspection and maintenance log in section 10.0 of this manual.

IMPORTANT: If this equipment has been subjected to forces resulting from the arrest of a fall, it must be immediately removed from service and destroyed or returned to DBI-SALA for possible repair. See section 5.2.

5.2 INSPECTION STEPS:

- Step 1. Check the base plates for excessive dents or deformations. Make sure the counterweights will lay flat on the base plates. Check the base plates for delamination of the rubber coating. If the coating has loose edges that may catch or double back on itself, the base plate should be replaced.

- Step 2. Inspect the LEAP Anchor for physical damage. Look carefully for any signs of cracks, dents or deformities in the metal. If the anchor has been subjected to fall arrest forces the upright cylinder will be tipped over to one side. Do not use an anchor that has been subjected to fall arrest forces.
- Step 3. Inspect the LEAP Anchor for signs of excessive corrosion.
- Step 4. Ensure the condition of the roof will support the LEAP Anchor loads, see section 2.4

5.3 If inspection reveals an unsafe or defective condition, remove the unit from service and destroy, or contact DBI-SALA for possible repair.

5.4 USER EQUIPMENT: Inspect each system component or subsystem (i.e. SRL, full body harness, lanyard, lifeline, etc.) per associated manufacturer’s instructions. Refer to manufacturer’s instruction supplied with each system component for inspection procedures.

6.0 MAINTENANCE, SERVICE, STORAGE

6.1 The Evolution Counterweight System components require no scheduled maintenance, other than repair or replacement of items found defective during inspection. See section 5.0. If components become heavily soiled with grease, paint, or other substances, clean with appropriate cleaning solutions. Do not use caustic chemicals that could damage system components.

7.0 SPECIFICATIONS

7.1 MATERIALS:
Base Plate: Rubber coated steel
Counterweights: Galvanized cast iron
L-bolts: Steel

7.2 WEIGHT:
Counterweight: 45 lbs.

8.0 TERMINOLOGY

AUTHORIZED PERSON: A person assigned by the employer to perform duties at a location where the person will be exposed to a fall hazard (otherwise referred to as “user” for the purpose of these instructions).

RESCUER: Person or persons other than the rescue subject acting to perform an assisted rescue by operation of a rescue system.

CERTIFIED ANCHORAGE: An anchorage for fall arrest, positioning, restraint, or rescue systems that a qualified person certifies to be capable of supporting the potential fall forces that could be encountered during a fall or that meet the criteria for a certified anchorage prescribed in this standard.

QUALIFIED PERSON: A person with a recognized degree or professional certificate and with extensive knowledge, training, and experience in the fall protection and rescue field who is capable of designing, analyzing, evaluating and specifying fall protection and rescue systems to the extent required by this standard.

COMPETENT PERSON: One who is capable of identifying existing and predictable hazards in the surroundings or working conditions which are unsanitary, hazardous, or dangerous to employees, and who has authorization to take prompt corrective measures to eliminate them.

9.0 LABELING

9.1 The following label must be present and fully legible:





A Capital Safety Company
Une filiale de Capital Safety
Una compañía de Capital Safety

USA

3833 SALA Way
Red Wing, MN 55066-5005
Toll Free: 800-328-6146
Phone: (651) 388-8282
Fax: (651) 388-5065
Email: solutions@capitalsafety.com
www.capitalsafety.com

Canada

260 Export Boulevard
Mississauga, Ontario L5S 1Y9
Toll Free: 800-387-7484
Phone: (905) 795-9333
Fax: (905) 795-8777
Email: solutions@capitalsafety.com
www.capitalsafety.com

This manual is available for download at www.capitalsafety.com.
Ce guide peut être téléchargé à www.capitalsafety.com
Este manual está disponible para ser descargado en www.capitalsafety.com.